

1. Application / Construction

Identification	OFC-12 G.657A1/G.657A2-DC-S1		
Application	Duct and aerial installation		
Cross Section (not to scale)	12fibers 		
Configuration	<ul style="list-style-type: none"> - Loose tube with 12 optical fibers and jelly inside - Aramid yarn(s) - Dielectric armor : round FRP - Outer sheath: PE, Anti-UV - Ripcord*2 under sheath 		
Temperature Range	Storage and transport -40 to +70°C	Installation -5 to +45°C	Operation -30 to +60°C
Standards	IEC 60793-1, IEC 60793-2, IEC 60794-4-20, EN 50290-2-24		
ZTT Specification	ZTT 20-109344-6-B		
Customer Reference	Common Standard		

2. Dimensions

Fiber counts		12
Outer diameter (± 0.3)	mm	5.8
Weight	kg	33

Sizes and values without tolerances are nominal values

3. Mechanical Properties

Fiber counts	12
MAT	800N
Crush	1000N/10cm
Static bending radius	15xOD
Impact	5Nm
Torsion	$\pm 180^\circ$

See Point 6: Test Methods

4. Marking

Fiber Colors	1 red	2 green	3 blue	4 yellow	5 white	6 grey	7 brown	8 purple	9 turquoise	10 black	11 orange	12 Pink
Tube Colors	1 red											

Outer Sheath: black, ink jet print, marking in 1 meter intervals as follows:

ZTT	Drop Cable 12	<Fiber Type>	<Batch No.>	<meter marking>
-----	---------------	--------------	-------------	-----------------



5. Optical Fiber

Standard	ITU-T G.657A1 UBIF®R10	
Optical	Fibre attenuation (after cabling) .. @ 1310 nm .. @ 1550 nm	≤0.36 dB/km ≤0.23 dB/km
	Zero Dispersion Wavelength	1300-1324nm
	Zero dispersion slope	≤0.092 ps/nm ² ·km
	Dispersion coefficient	≤3.5 ps/(nm·km)@1310nm ≤19 ps/(nm·km)@1550nm
	PMD Individual	≤0.2 ps/√km
	Cable cut-off wavelength	≤1260 nm
	Mode field diameter (MFD)	8.8 ± 0.4 μm@1310 nm
	Macro bending loss (1 turn Ø20 mm)	@1550 nm ≤0.75 dB @1625 nm ≤1.5 dB
Geometric	Cladding diameter	125 ± 0.7 μm
	Core/clad concentricity error	≤0.5 μm
	Cladding non-circularity	≤ 1.0 %
	Coating diameter (Colored)	250 ± 15 μm
Mechanical	Proof stress	≥ 0.69 Gpa

Standard	ITU-T G.657A2 UBIF®R7.5	
Optical	Fibre attenuation (after cabling) .. @ 1310 nm .. @ 1550 nm	≤0.36 dB/km ≤0.23 dB/km
	Zero Dispersion Wavelength	1300-1324nm
	Zero dispersion slope	≤0.092 ps/nm ² ·km
	Dispersion coefficient	≤3.5 ps/(nm·km)@1310nm ≤19 ps/(nm·km)@1550nm
	PMD Individual	≤0.2 ps/√km
	Cable cut-off wavelength	≤1260 nm
	Mode field diameter (MFD)	8.6 ± 0.4 μm@1310 nm
	Macro bending loss (1 turn Ø15 mm)	@1550 nm ≤0.5 dB @1625 nm ≤1.0 dB
Geometric	Cladding diameter	125 ± 0.7 μm
	Core/clad concentricity error	≤0.5 μm
	Cladding non-circularity	≤ 1.0 %
	Coating diameter (Colored)	250 ± 15 μm
Mechanical	Proof stress	≥ 0.69 Gpa

6. Test Methods

Test	Conditions	Acceptance criteria
Tension Loading IEC 60794-1-2 E1	Tensile strength: See point3 Tensioned length: ≥ 25 m, 10min	- Fiber strain ≤ 0.6%, by clamps - Δα reversible
Impact Resistance IEC 60794-1-2 E4	Radius =300 mm, number of places/tests: 3 Impact energy: 5 J	- Δα reversible
Static bending IEC 60794-1-2 E11A	R=15xOD, U bending, 3 cycles	- Δα reversible
Torsion/Twist IEC 60794-1-2 E7	Sample length:2m, Test condition: see Point 3, 10cycles	- Δα reversible

Crush/Compression IEC 60794-1-2 E3	Crush: see Point 3, 1min Number of tests: 3	- $\Delta\alpha$ reversible
Temperature cycling IEC 60794-1-2 F1	-30°C..+60°C t1=8h, 2 cycles	- $\Delta\alpha \leq 0.1$ dB/km
Water penetration IEC 60794-1-2 F5B	Sample length: 3 m, water column height: 1 m Test duration: 24 h,	- No leakage from cable core (Tube)

All optical measurements at 1550 nm

7. Stress-Sag Data Sheet

Cable Parameters:

Sl.	Description	Unit	Parameters
			12F
1	Overall diameter	mm	5.8
2	Sectional area	mm ²	5.66
3	Nominal weight	Kg/km	33
4	Modulus of elasticity	KN/mm ²	52.72
5	Coefficient of linear expansion	10 ⁻⁶ /°C	8.24

Sag Sheet [12F]:

Span	Installation*		NESC Light	
	Sag	Tension	Sag	Tension
M	%	N	%	N
40	1	170	2.39	560
50	1	210	2.53	660
60	1	250	2.65	750

Note:

1. Marked is installation state, ZTT designed the installation temperature 16°C, wind speed 5m/s and no ice coating.
2. ZTT design optical fiber cable would meet tension requirement under the worst weather conditions, and can be kept in good working condition

8. Logistics

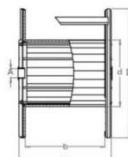
Cable type	Length (-1%/+3%)	2000m	 D*d*B in cm
OFC-12...-DC-S1	Drum type Dimensions Weight	Plywood 75*50*50 74kg	

Dimensions including protection. Indicative values, actually delivered drum sizes and weights may deviate. Cable ends sealed with caps

光緒

